

NAVIGATOR RT-4500

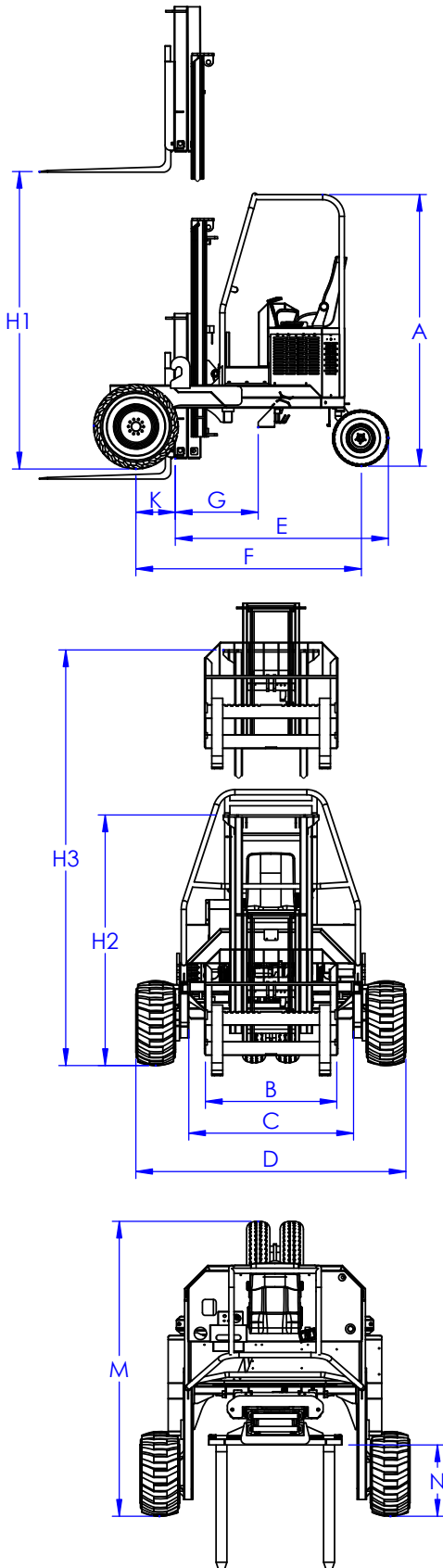

1	MODEL	RT-4500
2	TYPE	TWO WHEEL DRIVE
3	FRAME TYPE	EXTENDED
4	MAST	10' LIGHTWEIGHT NAV-REACH
5	CAPACITY @ 24" LOAD CENTER	4500 LBS
6	ENGINE	56 HP KOHLER DIESEL
7	ENGINE EMISSION COMPLIANCE	EPA TIER 4 FINAL
8	MAXIMUM RPM	2700 RPM
9	ELECTRICAL SYSTEM	12 VOLT
10	DRIVE WHEELS	2
11	STEERING	HYDRAULIC
12	TIRE TYPE	? ?
13	TIRE OUTSIDE DIAMETER (FRONT / REAR)	
14	TIRE WIDTH (FRONT / REAR)	
15	MAXIMUM SPEED	
16	MAXIMUM GRADABILITY	
17	TURNING RADIUS	
18	UNLADEN WEIGHT	
19	WORKING PRESSURE (ATTACHMENTS)	3100 PSI
20	TILT OF MAST (FORWARD / BACKWARD)	10° / 10°
21	SIDESHIFT	8"
22	FORK SECTION	48" X 6" X 2"
23	MAST CARRIAGE TRAVEL	
24	ANSI STANDARD	B56.14
A	HEIGHT TO TOP OF CANOPY	
B	FORK CARRIAGE WIDTH (CLASS)	48"
C	FRAME OPENING	60"
D	OVERALL FRAME WIDTH	66 3/4"
E	OVERHANG	
F	WHEELBASE	
G	CENTER OF GRAVITY (FROM FORK FACE)	
H1	LIFT HEIGHT	
H2	MAST HEIGHT - COLLAPSED	
H3	MAST HEIGHT - RAISED	
J	GROUND CLEARANCE	
K	FACE OF FORK TO CENTER OF FRONT TIRE	
M	OVERALL LENGTH	
N	FRONT FACE OF TIRE TO FACE OF FORK	

The above specifications are not binding upon the manufacturer and may be changed without prior notice. Weights may vary, depending on tire and/or fork options.

For more information, contact your local Navigator dealer.

Navigator Truck Mounted Forklifts
7399 Beatline Road
Long Beach, MS 39560 USA
tel 1.228.864.6293
www.NavigatorForklift.com

