

NAVIGATOR RT-5500

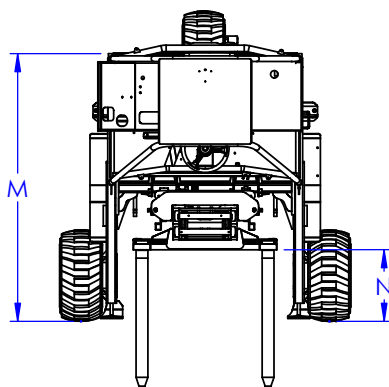
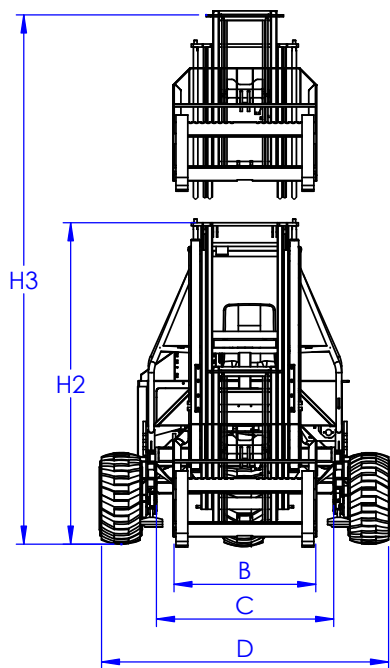
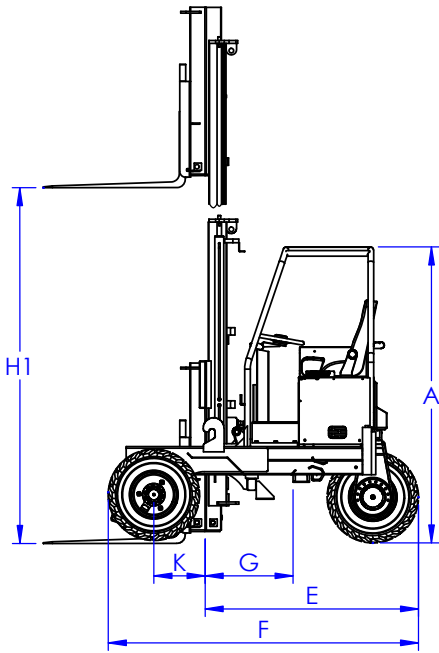

	MODEL	RT-5500
	TYPE	ALL WHEEL DRIVE
1	CAPACITY @ 24" LOAD CENTER	5500 LBS
2	DIESEL ENGINE	56 HP
3	ENGINE EMISSION COMPLIANCE	EPA Tier4 Final
4	MAXIMUM RPM	2700 RPM
5	ELECTRICAL SYSTEM	12 VOLT
6	DRIVE WHEELS	3
7	STEERING	HYDRAULIC
8	TIRE TYPE	31X13-16.5 (SS) 31X15.5-15 8-PLY (TG)
9	TIRE OUTSIDE DIAMETER (FRONT/REAR)	31.5"/31"
10	TIRE WIDTH (FRONT/REAR)	13"X15.5"
11	MAXIMUM SPEED	8 MPH
12	MAXIMUM GRADABILITY (4-WAY MODE)	N/A
13	TURNING RADIUS	
14	UNLADEN WEIGHT	
15	WORKING PRESSURE (ATTACHMENTS)	3100 PSI
16	TILT OF MAST (FORWARD/BACKWARD)	10° / 10°
17	SIDESHIFT	8"
18	FORK SECTION	48 X 6 X 2
19	MAST CARRIAGE TRAVEL	
A	HEIGHT TO TOP OF CANOPY	
B	FORK CARRIAGE WIDTH (CLASS)	48"
C	FRAME OPENING	
D	OVERALL FRAME WIDTH	
E	OVERHANG	
F	WHEELBASE	
G	CENTER OF GRAVITY (FROM FORK FACE)	
H1	LIFT HEIGHT	
H2	MAST HEIGHT - COLLAPSED	
H3	MAST HEIGHT - RAISED	
J	GROUND CLEARANCE	
K	FACE OF FORK TO CENTER OF FRONT TIRE	
L	ANSI STANDARD	B56.14
M	OVERALL LENGTH	
N	FRONT FACE OF TIRE TO FACE OF FORK	

The above specifications are not binding upon the manufacturer and may be changed without prior notice. Weights may vary, depending on tire and/or fork options.

For more information, contact your local Navigator dealer.

Navigator Truck Mounted Forklifts
7399 Beatline Road
Long Beach, MS 39560 USA
tel 1.228.864.6293
www.NavigatorForklift.com

