

# NAVIGATOR RT-5000

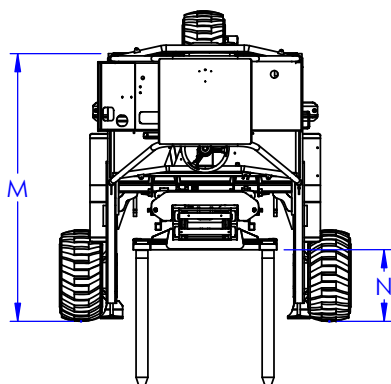
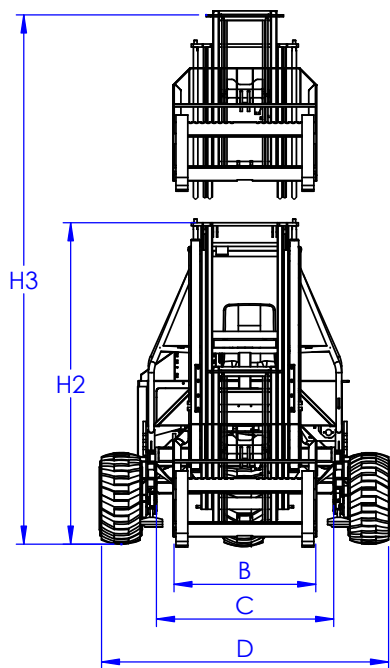
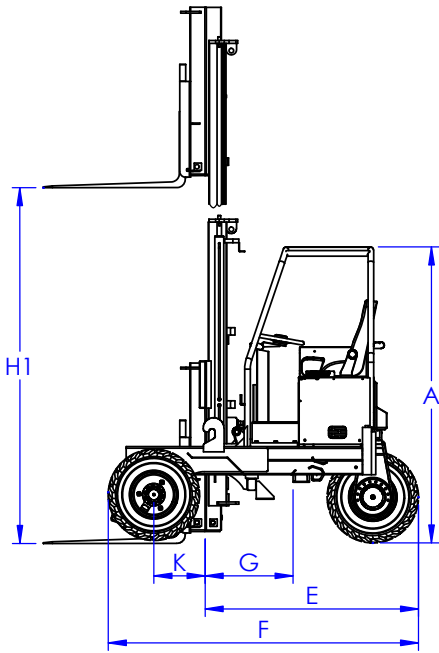

	MODEL	RT-5000
	TYPE	ALL WHEEL DRIVE
1	CAPACITY @ 24" LOAD CENTER	5000 LBS
2	DIESEL ENGINE	56 HP
3	ENGINE EMISSION COMPLIANCE	EPA Tier4 Final
4	MAXIMUM RPM	2700 RPM
5	ELECTRICAL SYSTEM	12 VOLT
6	DRIVE WHEELS	3
7	STEERING	HYDRAULIC
8	TIRE TYPE	31X13-16.5 (SS) 31X15.5-15 8-PLY (TG)
9	TIRE OUTSIDE DIAMETER (FRONT/REAR)	31.5"/31"
10	TIRE WIDTH (FRONT/REAR)	13"X15.5"
11	MAXIMUM SPEED	8 MPH
12	MAXIMUM GRADABILITY (4-WAY MODE)	N/A
13	TURNING RADIUS	78"
14	UNLADEN WEIGHT	5330 / 5636
15	WORKING PRESSURE (ATTACHMENTS)	3100 PSI
16	TILT OF MAST (FORWARD/BACKWARD)	10 ° / 10°
17	SIDESHIFT	8"
18	FORK SECTION	48 X 6 X 2
19	MAST CARRIAGE TRAVEL	30 / 37
A	HEIGHT TO TOP OF CANOPY	99"
B	FORK CARRIAGE WIDTH (CLASS)	48"
C	FRAME OPENING	60"
D	OVERALL FRAME WIDTH	100"
E	OVERHANG	67" / 83"
F	WHEELBASE	112"
G	CENTER OF GRAVITY (FROM FORK FACE)	27" / 32"
H1	LIFT HEIGHT	144"
H2	MAST HEIGHT - COLLAPSED	103" / 108"
H3	MAST HEIGHT - RAISED	202"
J	GROUND CLEARANCE	11"
K	FACE OF FORK TO CENTER OF FRONT TIRE	16"
L	ANSI STANDARD	B56.14
M	OVERALL LENGTH	92" / 98"
N	FRONT FACE OF TIRE TO FACE OF FORK	30"

The above specifications are not binding upon the manufacturer and may be changed without prior notice. Weights may vary, depending on tire and/or fork options.

**Navigator Truck Mounted Forklifts**  
**7399 Beatline Road**  
**Long Beach, MS 39560 USA**  
**tel 1.228.864.6293**  
**www.NavigatorForklift.com**



For more information, contact your local Navigator dealer.