

NAVIGATOR RT-5500

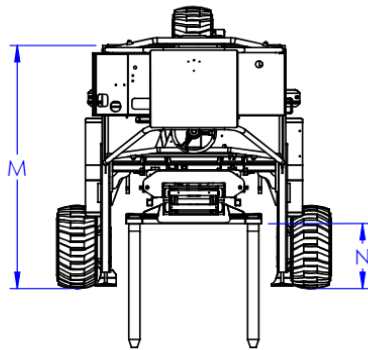
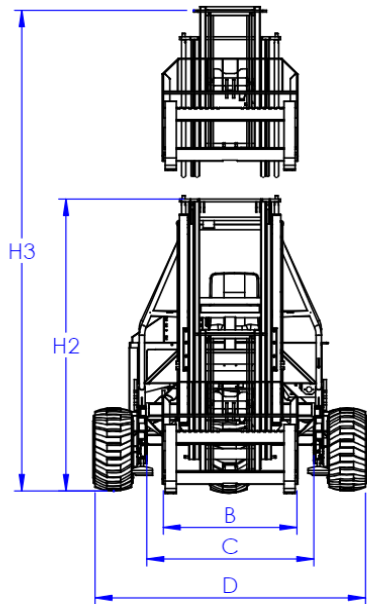
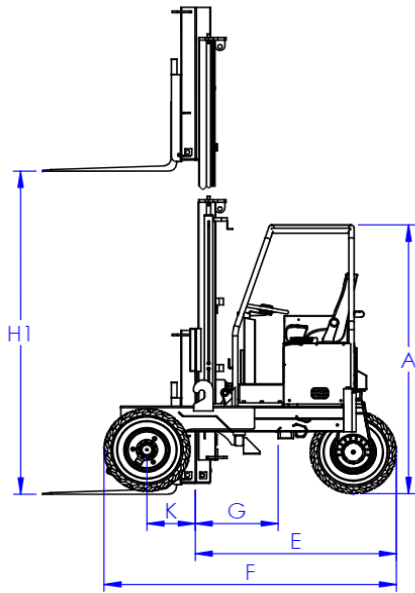

	MODEL	RT-5500
	TYPE	ALL WHEEL DRIVE
	FRAME TYPE	STANDARD/EXTENDED
	MAST	12' MAST/ 12' WITH NAV. REACH
1	CAPACITY@24" LOAD CENTER	5500 LBS.
2	KOHLER DIESEL ENGINE	56 HP
3	ENGINE EMISSION COMPLIANCE	EPA TIER 4 FINAL
4	MAXIMUM RPM	2700 RPM
5	ELECTRICAL SYSTEM	12 VOLT
6	DRIVE WHEELS	3
7	STEERING	HYDRAULIC
8	TIRE SIZE	31X13-16.5 (SS) 31X15.5-15 8-PLY
9	TIRE OUTSIDE DIAMETER	31.5"/31"
10	TIRE WIDTH (FRONT/REAR)	13" / 15.5"
11	MAXIMUM SPEED	8 MPH
12	MAXIMUM GRADABILITY	N/A
13	TURNING RADIUS	78"/84"
14	UNLADEN WEIGHT	6070 LBS./6980 LBS.
15	WORKING PRESSURE (ATTACHMENTS)	3100 PSI.
16	TILT OF MAST (FORWARD/BACKWARD)	10° /10°
17	SIDESHIFT	5"
18	STANDARD FORK	2X5X48
19	MAST CARRIAGE TRAVEL	30" /37"
A	HEIGHT TO TOP OF CANOPY	99"
B	FORK CARRIAGE WIDTH (CLASS)	48" CLASS 3
C	FRAME OPENING	60"
D	OVERALL FRAME WIDTH	100"
E	OVERHANG	67" / 83"
F	WHEELBASE	112"
G	CENTER OF GRAVITY (FROM FORK FACE)	27" / 32"
H1	LIFT HEIGHT	144"
H2	MAST HEIGHT-COLLAPSED	108"
H3	MAST HEIGHT-RAISED	202"
J	GROUND CLEARANCE	11"
K	FACE OF FORK TO CENTER OF FRONT TIRE	18.5"
L	ANSI STANDARD	B56.14
M	OVERALL LENGTH	91"/98"
N	FRONT FACE OF TIRE TO FRONT FACE OF FORK	30"

The above specifications are not binding upon the manufacturer and may be changed without prior notice. Weights may vary depending on tire and or fork options.

For more information, contact your local Navigator dealer.

Navigator Truck Mounted Forklifts
7399 Beatline Road
Long Beach, MS 39560 USA
tel 1.228.864.6293
www.NavigatorForklift.com

