

NAVIGATOR DT-4500

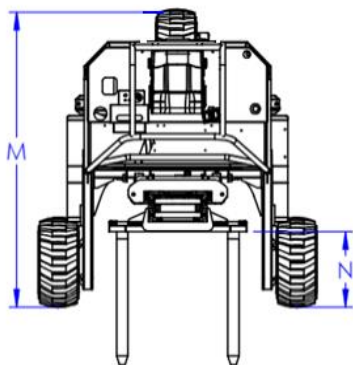
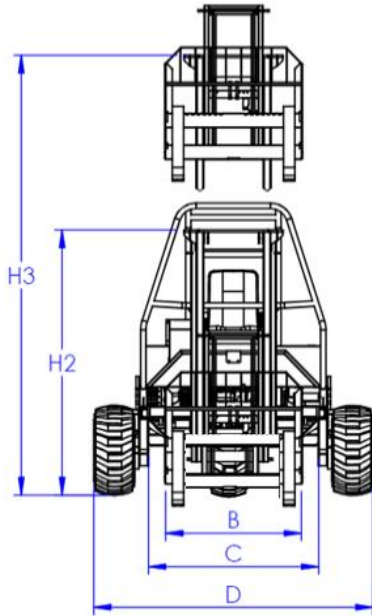
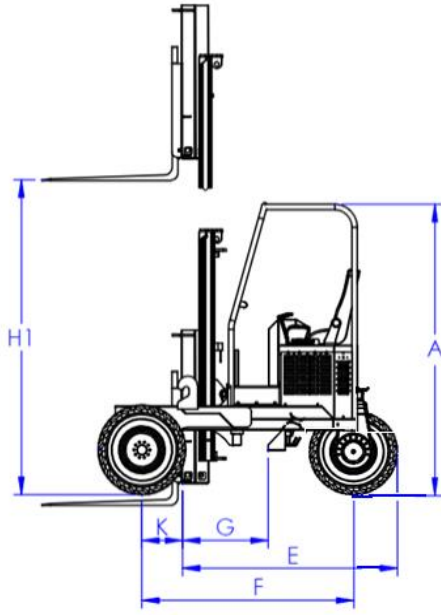

	MODEL	DT-4500
	TYPE	3 WHEEL DRIVE
	FRAME TYPE	STANDARD/EXTENDED
	MAST	10" LIGHTWEIGHT/ NAV REACH OPTIONAL
1	CAPACITY@24" LOAD CENTER	4500 LBS
2	ENGINE	56 HP KOHLER DIESEL
3	ENGINE EMISSION COMPLIANCE	EPA TIER 4 FINAL
4	MAXIMUM RPM	2700 RPM
5	ELECTRICAL SYSTEM	12 VOLT
6	DRIVE WHEELS	3
7	STEERING	HYDRAULIC
8	TIRE SIZE	29X12.5-15
9	TIRE OUTSIDE DIAMETER	29"
10	TIRE WIDTH (FRONT/REAR)	12.5"
11	MAXIMUM SPEED	8 MPH
12	MAXIMUM GRADABILITY	30%
13	TURNING RADIUS	100"/106"
14	UNLADEN WEIGHT	5060 lbs. / 5312 lbs.
15	WORKING PRESSURE (ATTACHMENTS)	3100 psi.
16	TILT OF MAST (FORWARD/BACKWARD)	10° / 10°
17	STANDARD FORK	2x4x48
18	MAST CARRAIGE TRAVEL	30" / 37"
A	HEIGHT TO TOP OF CANOPY	101"
B	FORK CARRAIGE WIDTH (CLASS)	48"
C	FRAME OPENING	60"
D	OVERALL WIDTH	93"
E	OVERHANG	78" / 83"
F	WHEELBASE	76"/81"
G	CENTER OF GRAVITY (FROM FORK FACE)	24"/31"
H1	LIFT HEIGHT	120"
H2	MAST HEIGHT-COLLAPSED	92"
H3	MAST HEIGHT-RAISED	150"
J	GROUND CLEARANCE	10.5"
K	FACE OF FORK TO CENTER OF FRONT TIRE	14" / 13"
L	ANSI STANDARD	B56.14
M	OVERALL LENGTH	103"/ 108"
N	FRONT FACE OF TIRE TO FRONT FACE OF FORK	30"

The above specifications are not binding upon the manufacturer and may be changed without prior notice. Weights may vary depending on tire and or fork options.

Navigator Truck Mounted Forklifts
7399 Beatline Road
Long Beach, MS 39560 USA
tel 1.228.864.6293
www.NavigatorForklift.com



For more information, contact your local Navigator dealer.