

# NAVIGATOR RT-4500

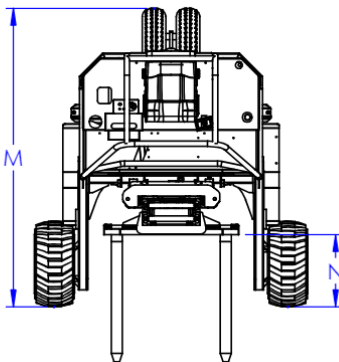
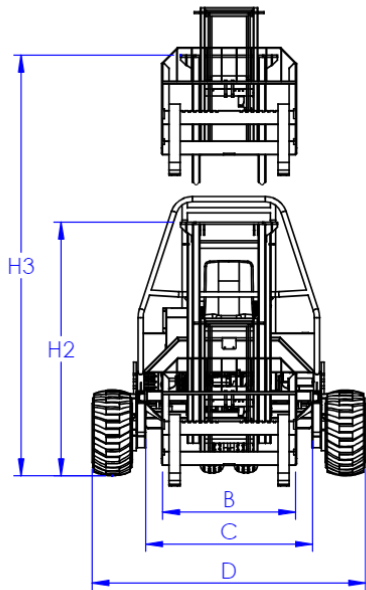
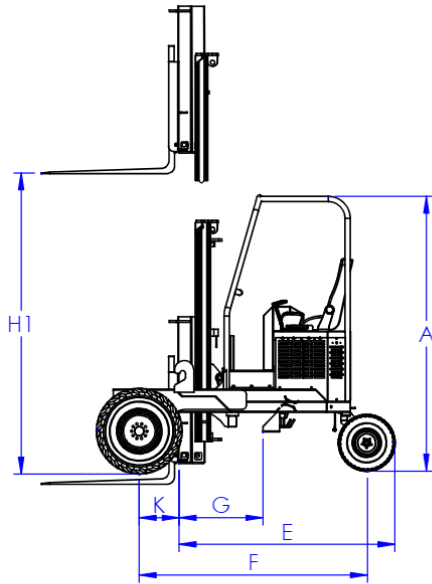

	MODEL	RT-4500
	TYPE	TWO WHEEL DRIVE
	FRAME TYPE	STANDARD/EXTENDED
	MAST	10" LIGHTWEIGHT NAV REACH OPTIONAL
1	CAPACITY@24" LOAD CENTER	4500 LBS
2	ENGINE	56 HP KOHLER DIESEL
3	ENGINE EMISSION COMPLIANCE	EPA TIER 4 FINAL
4	MAXIMUM RPM	2700 RPM
5	ELECTRICAL SYSTEM	12 VOLT
6	DRIVE WHEELS	2
7	STEERING	HYDRAULIC
8	TIRE SIZE	31X15.5-15/205-65-10
9	TIRE OUTSIDE DIAMETER	31"/20"
10	TIRE WIDTH (FRONT/REAR)	15.5"/8.25"
11	MAXIMUM SPEED	8 MPH
12	MAXIMUM GRADABILITY	N/A
13	TURNING RADIUS	110"/115"
14	UNLADEN WEIGHT (approximate)	4,582 lbs. / 4,882 lbs.
15	WORKING PRESSURE (ATTACHMENTS)	3100 psi.
16	TILT OF MAST (FORWARD/BACKWARD)	10° / 10°
17	SIDESHIFT (optional)	5"
18	STANDARD FORK	2x4x48
19	MAST CARRIAGE TRAVEL	30" / 37"
A	HEIGHT TO TOP OF CANOPY	101"
B	FORK CARRIAGE WIDTH (CLASS)	48"
C	FRAME OPENING	60"
D	OVERALL FRAME WIDTH	66.75"
E	OVERHANG	64" / 69"
F	WHEELBASE	87" / 92"
G	CENTER OF GRAVITY (FROM FORK FACE)	24"
H1	LIFT HEIGHT	10'
H2	MAST HEIGHT-COLLAPSED	92"
H3	MAST HEIGHT-RAISED	12'6"
J	GROUND CLEARANCE	10.5"
K	FACE OF FORK TO CENTER OF FRONT TIRE	14" / 13"
L	ANSI STANDARD	B56.14
M	OVERALL LENGTH	112" / 117"
N	FRONT FACE OF TIRE TO FRONT FACE OF FORK	30"

The above specifications are not binding upon the manufacturer and may be changed without prior notice. Weights may vary depending on tire and/or fork options.

For more information, contact your local Navigator dealer.

Navigator Truck Mounted Forklifts  
7399 Beatline Road  
Long Beach, MS 39560 USA  
tel 1.228.864.6293  
www.NavigatorForklift.com

