

NAVIGATOR RT-5500

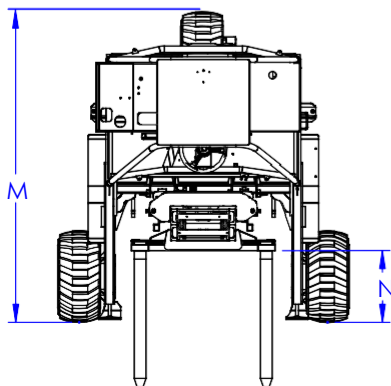
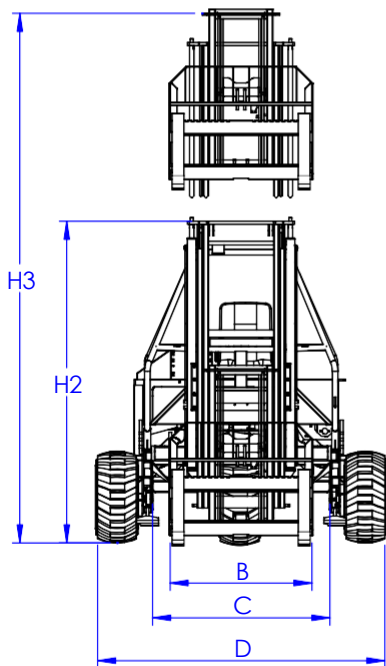
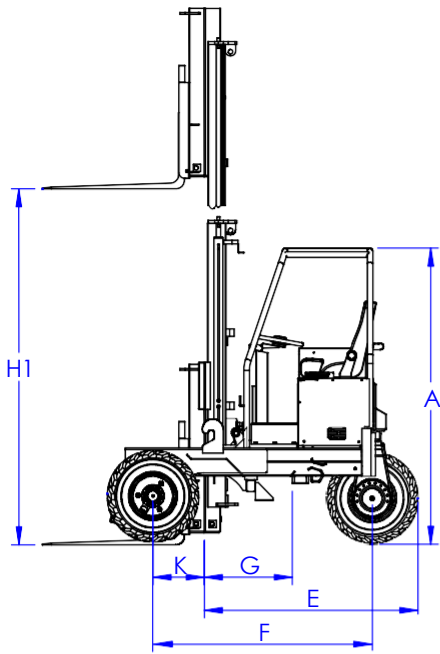

	MODEL	RT- 5500
	TYPE	Standard/Nav-Reach
1	CAPACITY @ 24" LOAD CENTER	5500 LBS
2	DIESEL ENGINE	56 HP Kohler
3	ENGINE EMISSION COMPLIANCE	EPA Tier4 Final
4	MAXIMUM RPM	2700 RPM
5	ELECTRICAL SYSTEM	12 VOLT
6	DRIVE WHEELS	3
7	STEERING	HYDRAULIC
8	TIRE TYPE	31X15.5-15 HIPPO
9	TIRE OUTSIDE DIAMETER (FRONT/REAR)	31"
10	TIRE WIDTH (FRONT/REAR)	13"X15.5"
11	MAXIMUM SPEED	8 MPH
12	MAXIMUM GRADABILITY (4-WAY MODE)	N/A
13	TURNING RADIUS	105"/111"
14	UNLADEN WEIGHT (approximate)	6,070LBS/6,980LBS
15	WORKING PRESSURE (ATTACHMENTS)	3100 PSI
16	TILT OF MAST (FORWARD/BACKWARD)	10 ° / 10°
17	SIDESHIFT	5"
18	STANDARD FORK	2"X5"X48"
19	MAST CARRIAGE TRAVEL	30'/37"
A	HEIGHT TO TOP OF CANOPY	99"
B	FORK CARRIAGE WIDTH (CLASS)	48" CLASS 3
C	FRAME OPENING	60"
D	OVERALL FRAME WIDTH	100"
E	OVERHANG	76"/ 83"
F	WHEELBASE	76"/ 83"
G	CENTER OF GRAVITY (FROM FORK FACE)	27"/ 32"
H1	LIFT HEIGHT	144"
H2	MAST HEIGHT - COLLAPSED	108"
H3	MAST HEIGHT - RAISED	202"
J	GROUND CLEARANCE	11"
K	FACE OF FORK TO CENTER OF FRONT TIRE	16"
L	ANSI STANDARD	B56.14
M	OVERALL LENGTH	105"/112"
N	FRONT FACE OF TIRE TO FACE OF FORK	30"

The above specifications are not binding upon the manufacturer and may be changed without prior notice. Weights may vary, depending on tire and/or fork options.

Navigator Truck Mounted Forklifts
7399 Beatline Road
Long Beach, MS 39560 USA
tel 1.228.864.6293
www.NavigatorForklift.com



For more information, contact your local Navigator dealer.